

UNIVERSITY PHYSICS

Chapter 5 NEWTON'S LAWS OF MOTION

PowerPoint Image Slideshow

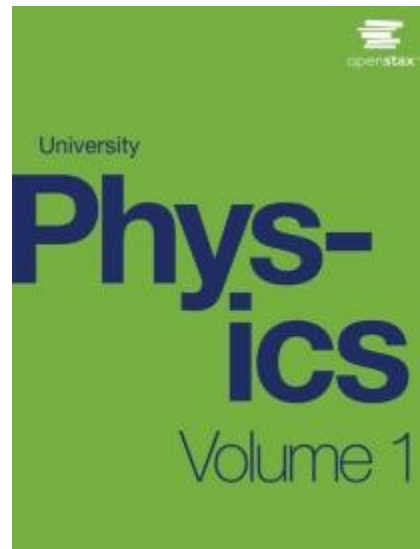

Free Body Diagrams

FIGURE 5.3

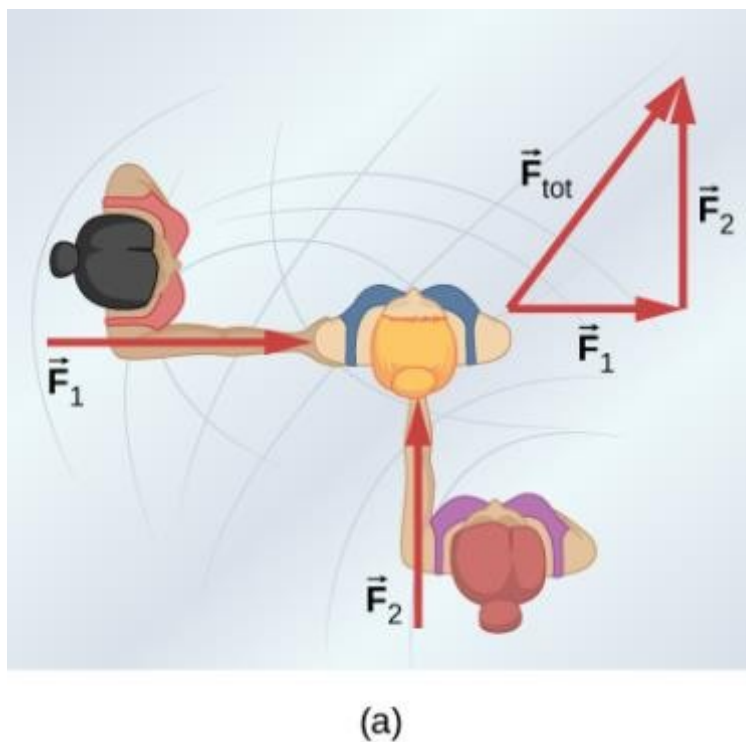

Free-body diagram

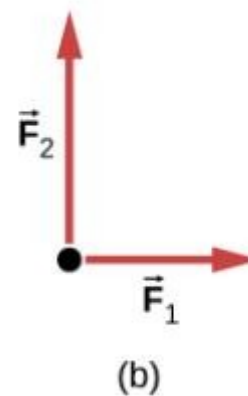

- a) An overhead view of two ice skaters pushing on a third skater. Forces are vectors and add like other vectors, so the total force on the third skater is in the direction shown.
- b) A free-body diagram representing the forces acting on the third skater.

FIGURE 5.4

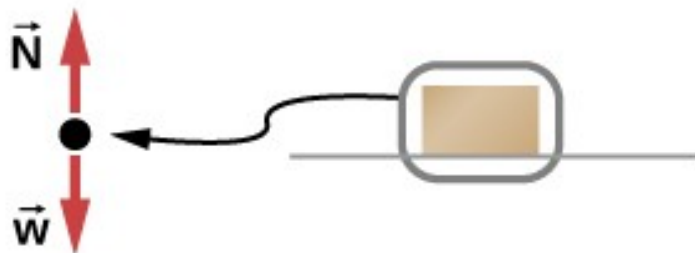

(a) Box at rest on a horizontal surface

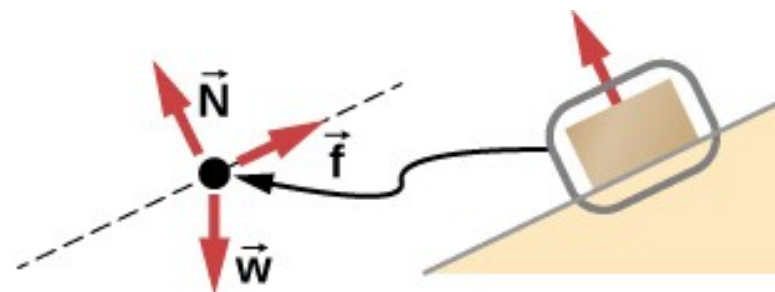

(b) Box on an inclined plane

In these free-body diagrams, \vec{N} is the normal force, \vec{w} is the weight of the object, and \vec{f} is the friction.

FIGURE 5.5

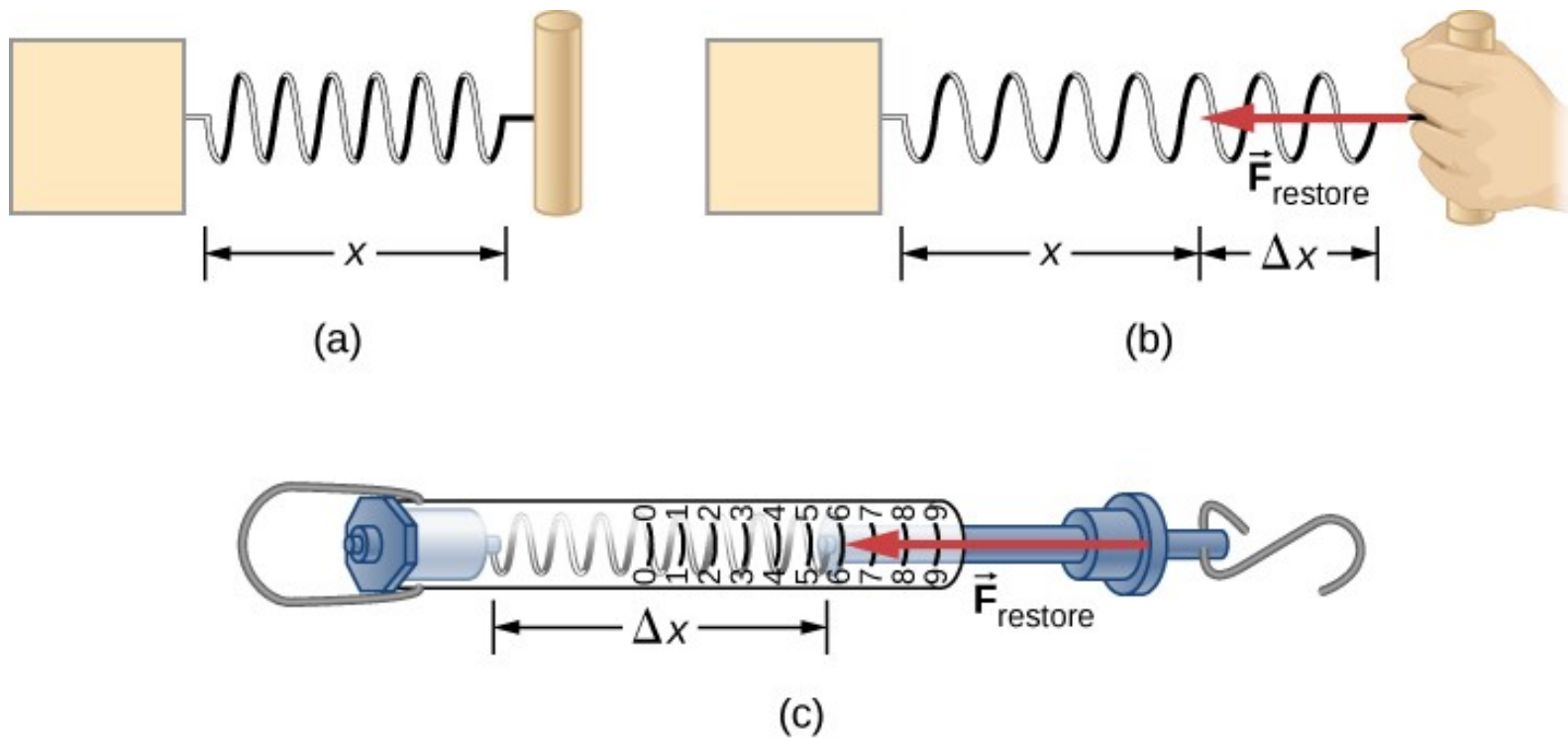

The force exerted by a stretched spring can be used as a standard unit of force.

- This spring has a length x when undistorted.
- When stretched a distance Δx , the spring exerts a restoring force $\vec{F} = -k\Delta x$, which is reproducible.
- A spring scale is one device that uses a spring to measure force. The force is exerted on whatever is attached to the hook. Here, this force has a magnitude of six units of the force standard being employed.

FIGURE 5.6

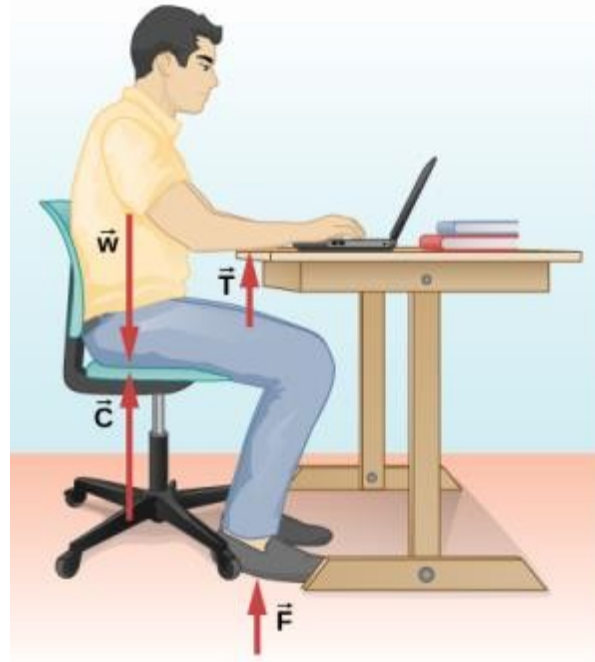

(a)



(b)

- The forces acting on the student are due to the chair, the table, the floor, and Earth's gravitational attraction.
- In solving a problem involving the student, we may want to consider the forces acting along the line running through his torso. A free-body diagram for this situation is shown.

FIGURE 5.7



(a)

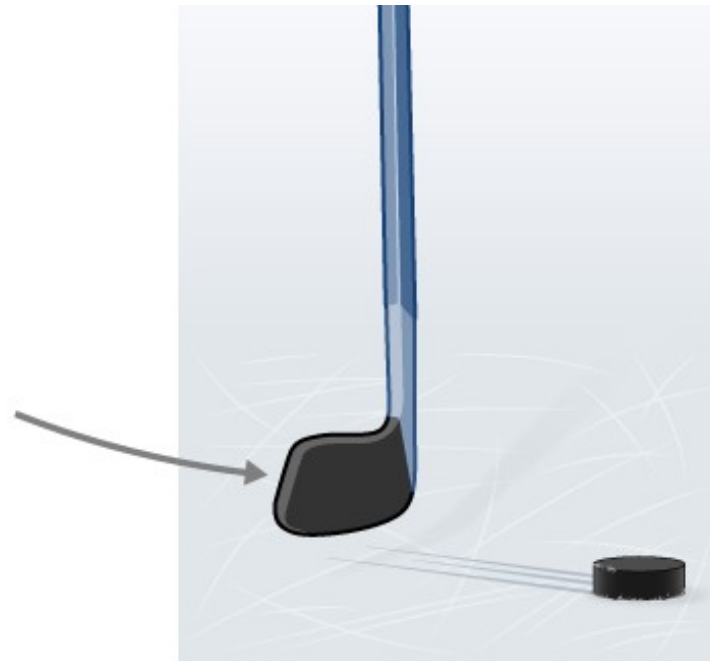

(b)

- a) A hockey puck is shown at rest; it remains at rest until an outside force such as a hockey stick changes its state of rest;
- b) a hockey puck is shown in motion; it continues in motion in a straight line until an outside force causes it to change its state of motion. Although it is slick, an ice surface provides some friction that slows the puck.

FIGURE 5.8

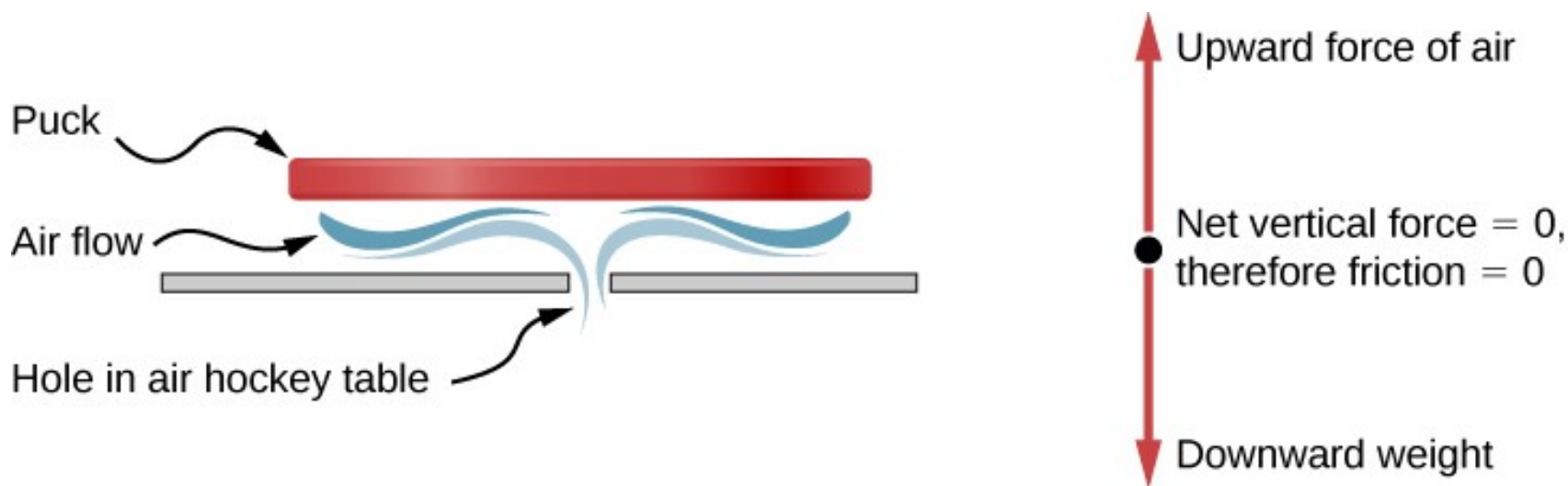

An air hockey table is useful in illustrating Newton's laws. When the air is off, friction quickly slows the puck; but when the air is on, it minimizes contact between the puck and the hockey table, and the puck glides far down the table.

Newton's Second Law

$$\vec{F} = m \vec{a}$$

FIGURE 5.9

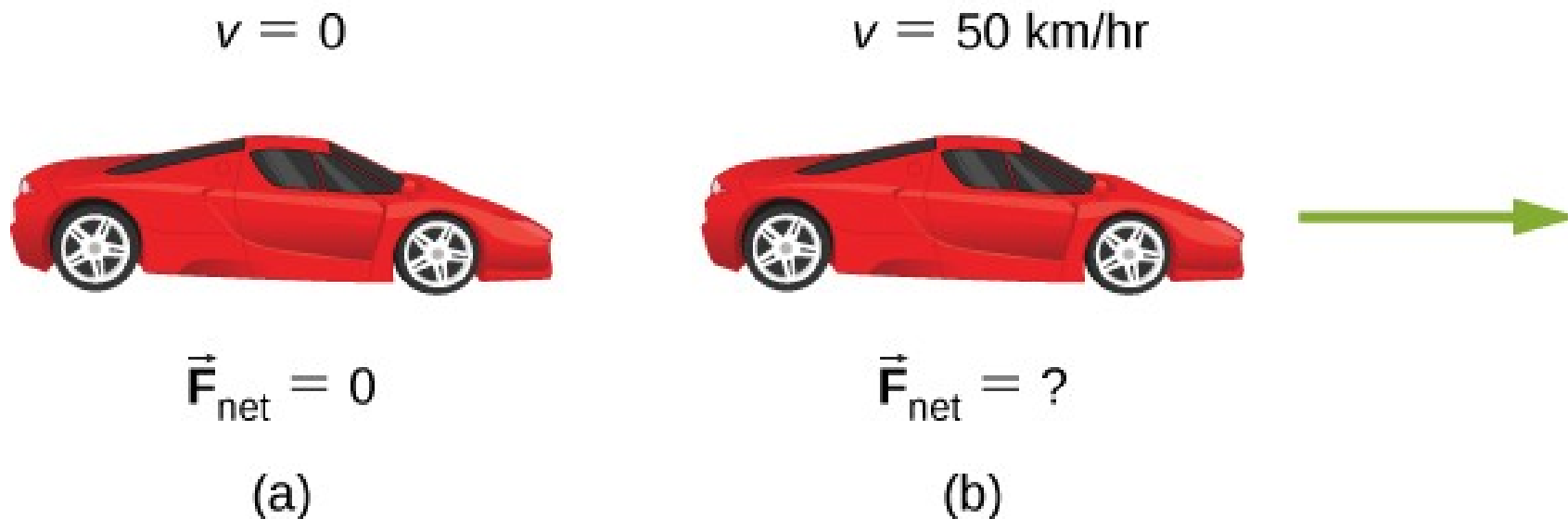

A car is shown (a) parked and (b) moving at constant velocity. How do Newton's laws apply to the parked car? What does the knowledge that the car is moving at constant velocity tell us about the net horizontal force on the car?

FIGURE 5.10

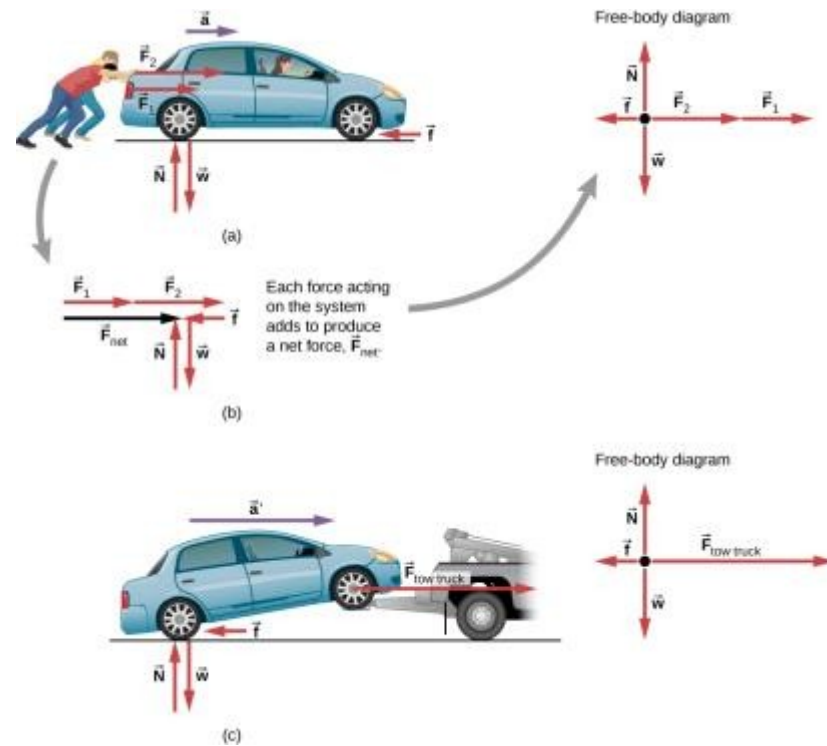

Different forces exerted on the same mass produce different accelerations.

- a) Two students push a stalled car. All external forces acting on the car are shown.
- b) The forces acting on the car are transferred to a coordinate plane (free-body diagram) for simpler analysis.
- c) The tow truck can produce greater external force on the same mass, and thus greater acceleration.

FIGURE 5.11

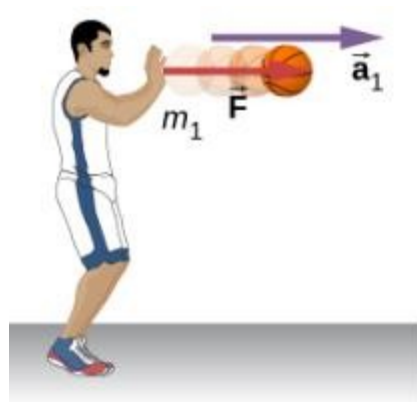

(a)



(b)

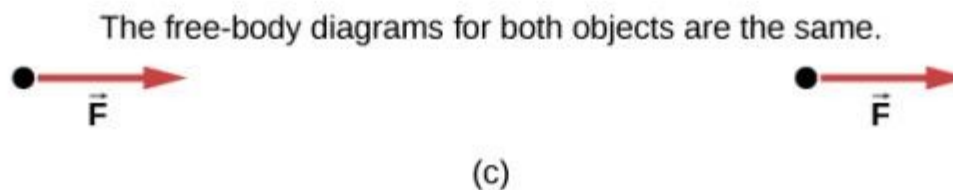

The same force exerted on systems of different masses produces different accelerations.

- a) A basketball player pushes on a basketball to make a pass. (Ignore the effect of gravity on the ball.)
- b) The same player exerts an identical force on a stalled SUV and produces far less acceleration.
- c) The free-body diagrams are identical, permitting direct comparison of the two situations. A series of patterns for free-body diagrams will emerge as you do more problems and learn how to draw them in [Drawing Free-Body Diagrams](#).

FIGURE 5.12



(a)

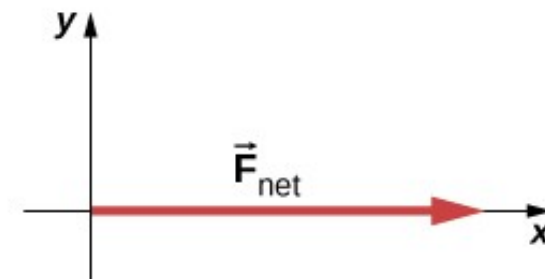

(b)

- a) The net force on a lawn mower is 51 N to the right. At what rate does the lawn mower accelerate to the right?
- b) The free-body diagram for this problem is shown.

FIGURE 5.13

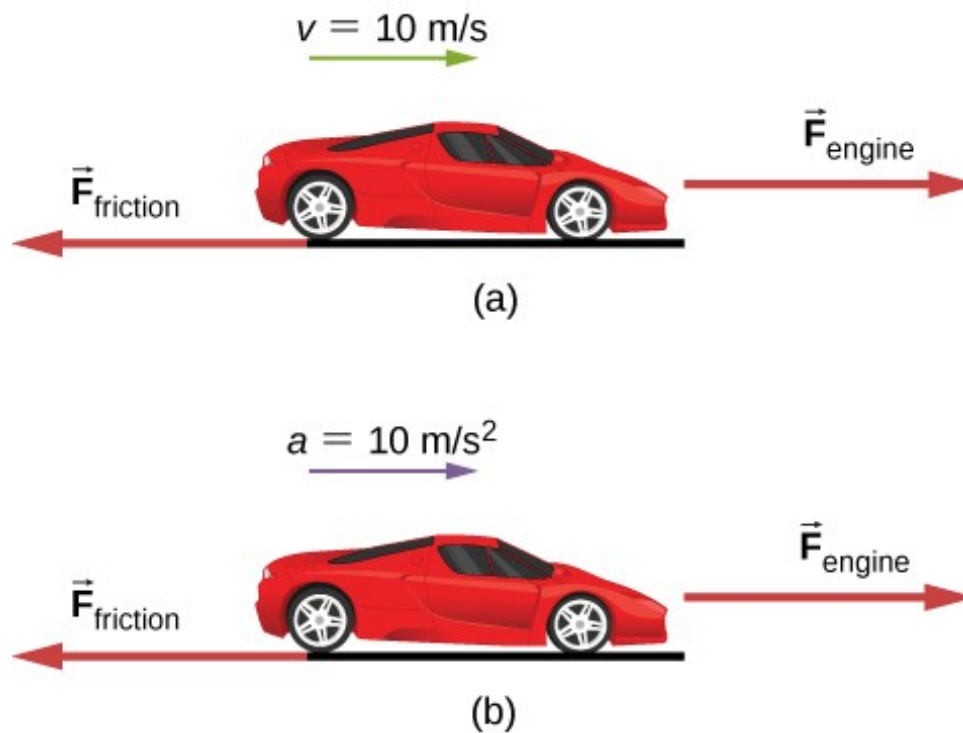

A car is shown (a) moving at constant speed and (b) accelerating. How do the forces acting on the car compare in each case?

- What does the knowledge that the car is moving at constant velocity tell us about the net horizontal force on the car compared to the friction force?
- What does the knowledge that the car is accelerating tell us about the horizontal force on the car compared to the friction force?

FIGURE 5.14

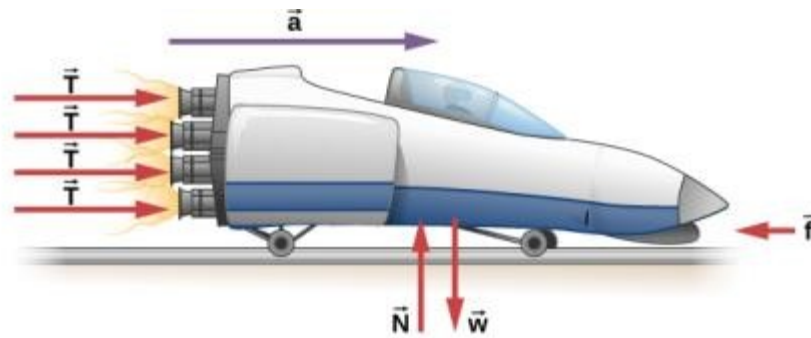

A sled experiences a rocket thrust that accelerates it to the right. Each rocket creates an identical thrust T . The system here is the sled, its rockets, and its rider, so none of the forces between these objects are considered. The arrow representing friction (f) is drawn larger than scale.

Free-body diagram

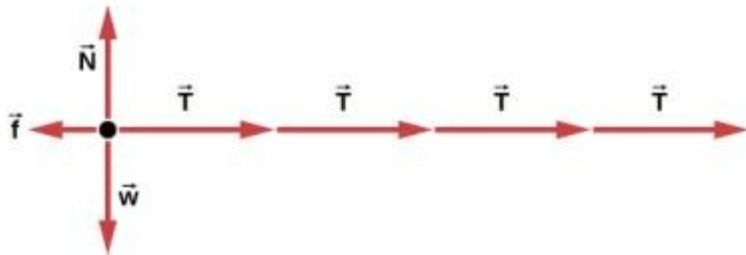

Four forces in the xy -plane are applied to a 4.0-kg particle.

FIGURE 5.15

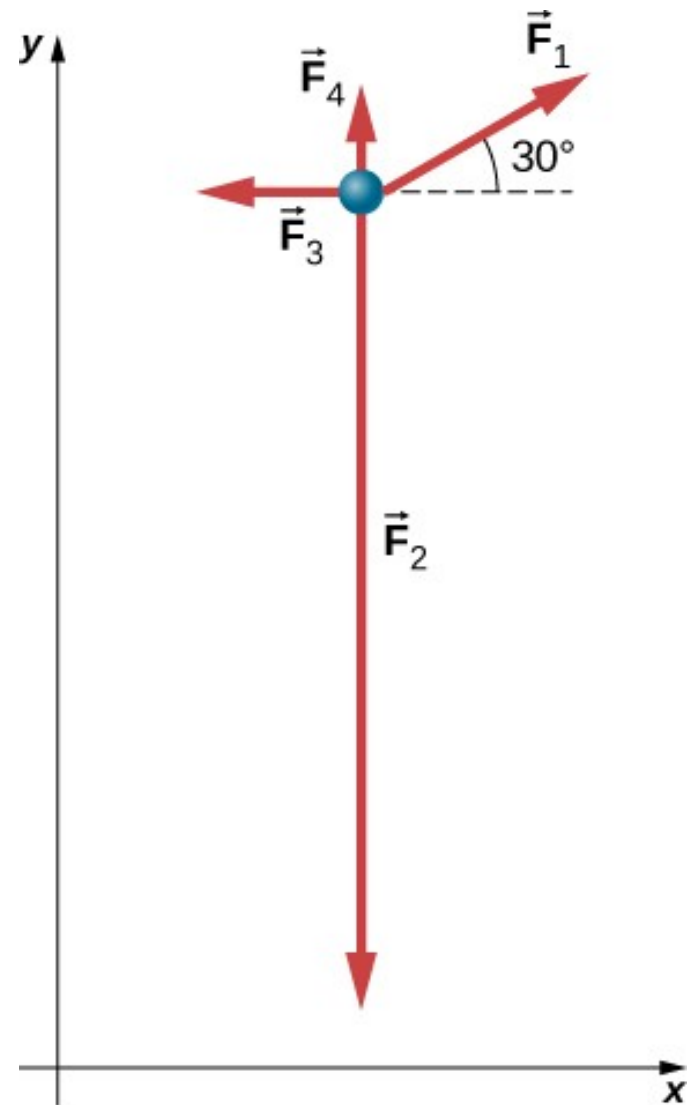

EXAMPLE 5.7

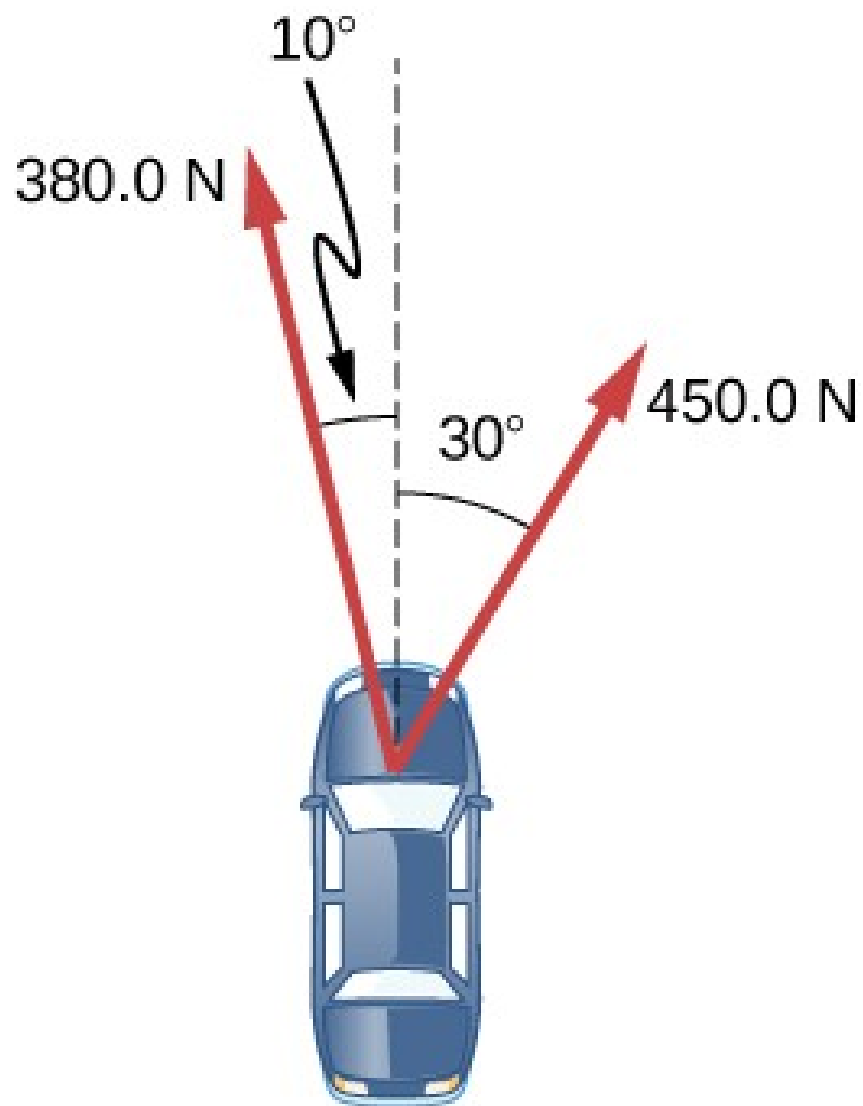

EXAMPLE 5.8

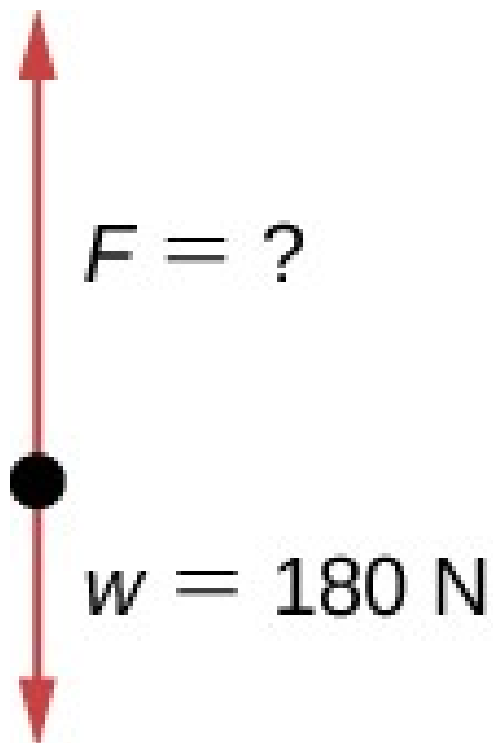



$a = 1.5 \text{ m/s}^2$

FIGURE 5.16

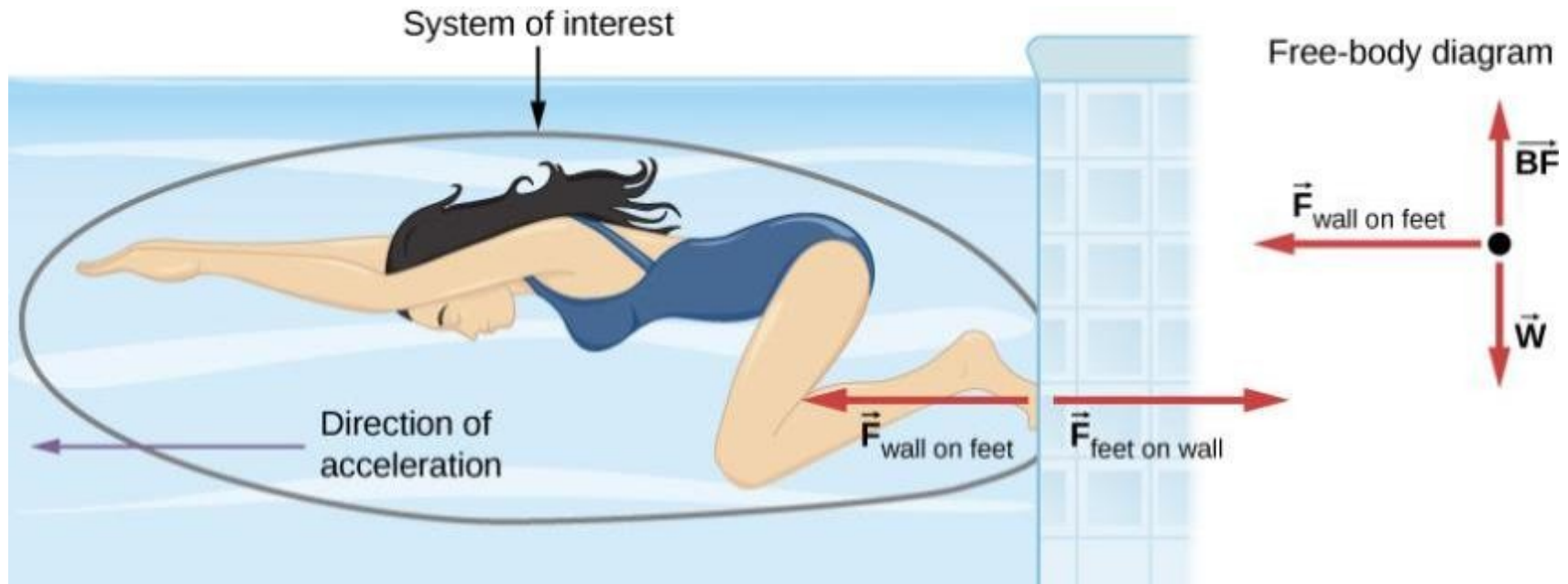

When the swimmer exerts a force on the wall, she accelerates in the opposite direction; in other words, the net external force on her is in the direction opposite of $\vec{F}_{\text{feet on wall}}$. This opposition occurs because, in accordance with Newton's third law, the wall exerts a force $\vec{F}_{\text{wall on feet}}$ on the swimmer that is equal in magnitude but in the direction opposite to the one she exerts on it. The line around the swimmer indicates the system of interest. Thus, the free-body diagram shows only $\vec{F}_{\text{wall on feet}}$, w (the gravitational force), and BF , which is the buoyant force of the water supporting the swimmer's weight. The vertical forces w and BF cancel because there is no vertical acceleration.

FIGURE 5.19

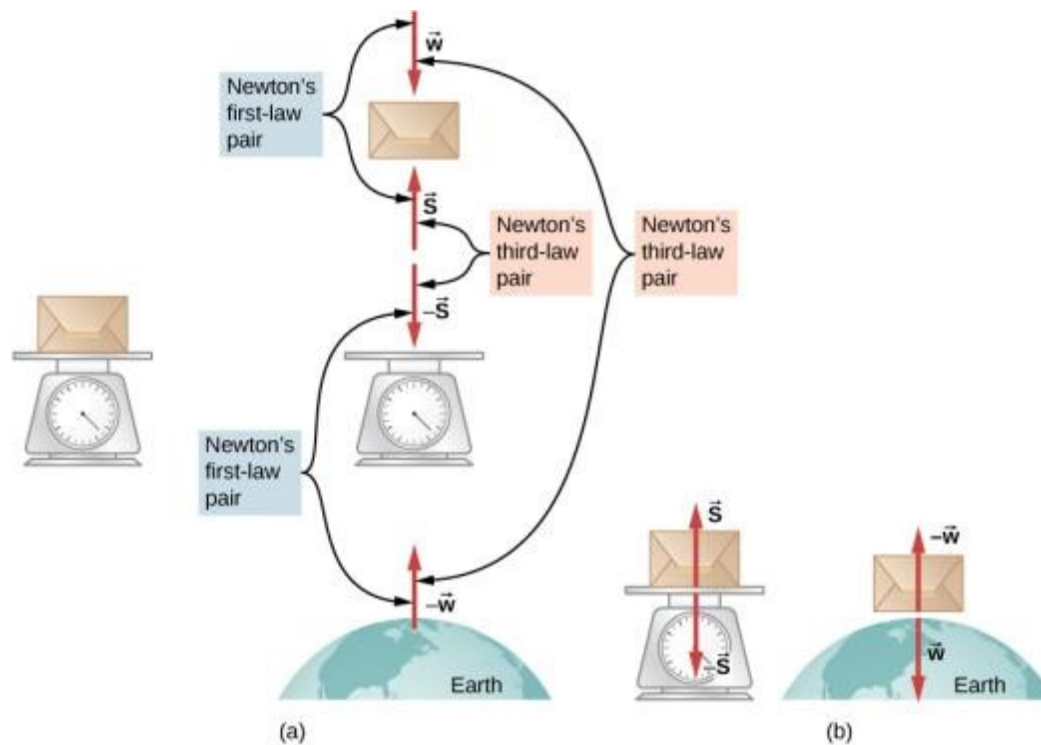

- The forces on a package sitting on a scale, along with their reaction forces. The force \vec{w} is the weight of the package (the force due to Earth's gravity) and \vec{S} is the force of the scale on the package.
- Isolation of the package-scale system and the package-Earth system makes the action and reaction pairs clear.

FIGURE 5.20

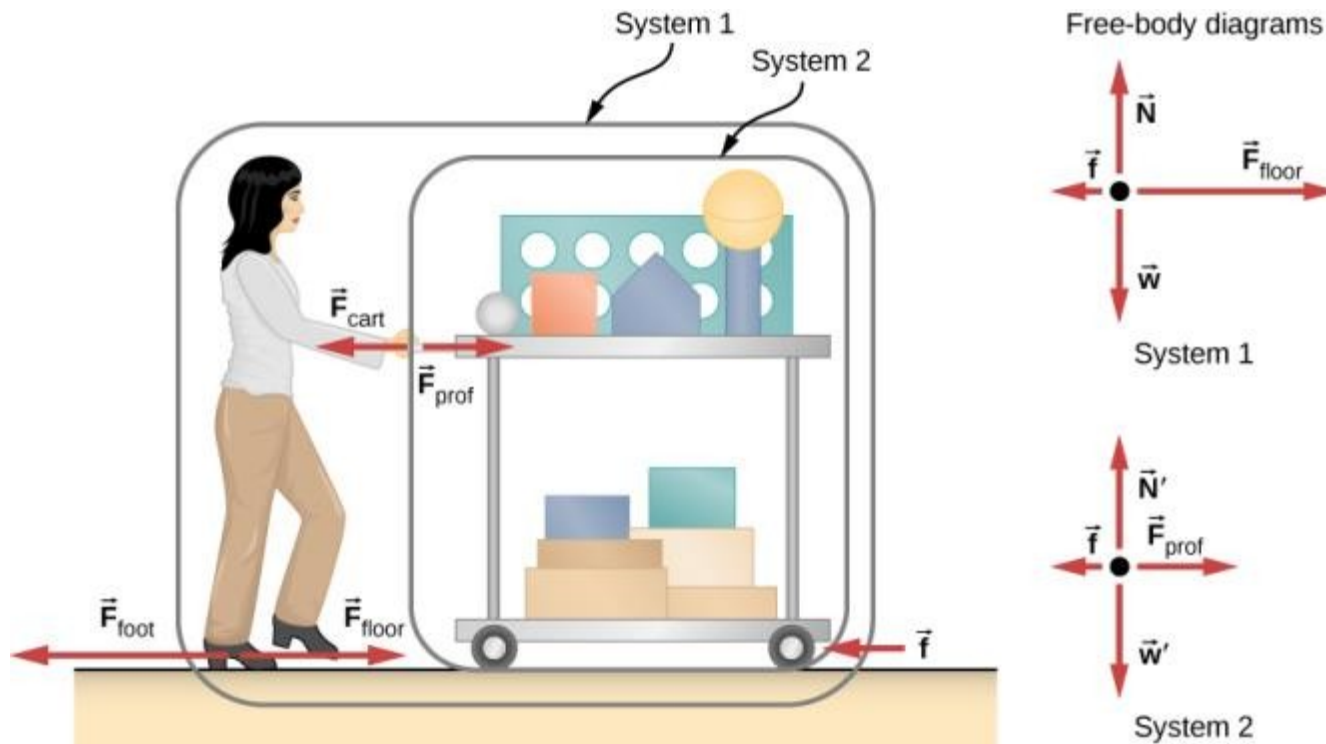

A professor pushes the cart with her demonstration equipment. The lengths of the arrows are proportional to the magnitudes of the forces (except for \vec{f} , because it is too small to draw to scale). System 1 is appropriate for this example, because it asks for the acceleration of the entire group of objects. Only \vec{F}_{floor} and \vec{f} are external forces acting on System 1 along the line of motion. All other forces either cancel or act on the outside world. System 2 is chosen for the next example so that \vec{F}_{prof} is an external force and enters into Newton's second law. The free-body diagrams, which serve as the basis for Newton's second law, vary with the system chosen.

The inclined plane

FIGURE 5.22

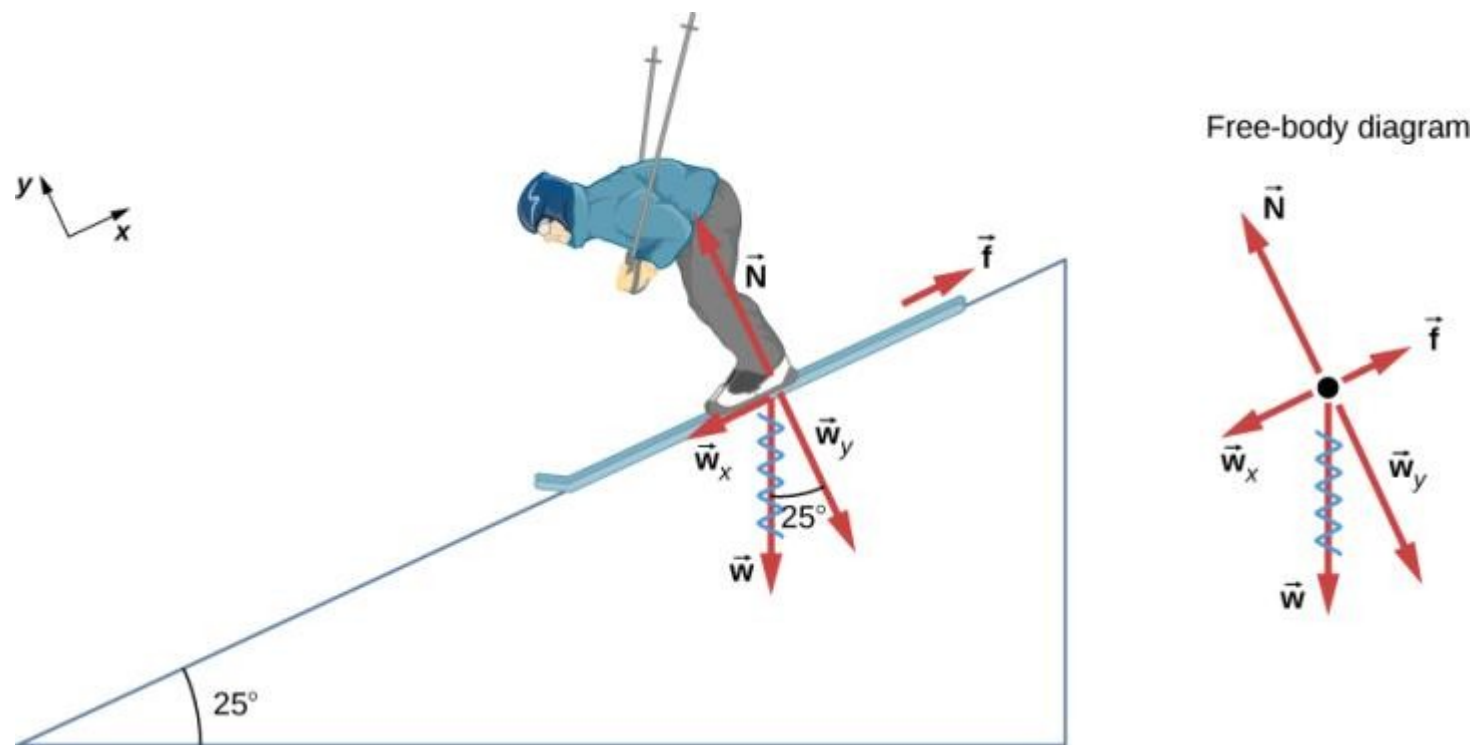

Since the acceleration is parallel to the slope and acting down the slope, it is most convenient to project all forces onto a coordinate system where one axis is parallel to the slope and the other is perpendicular to it (axes shown to the left of the skier). The weight vector \vec{w} is perpendicular to the slope and is parallel to the slope, but has components along both axes, namely, w_y and w_x . Here, \vec{w}_y has a squiggly line to show that it has been replaced by these components. The force is equal in magnitude to w_y , so there is no acceleration perpendicular to the slope, but f is less than w_x , so there is a downslope acceleration (along the axis parallel to the slope).

FIGURE 5.23

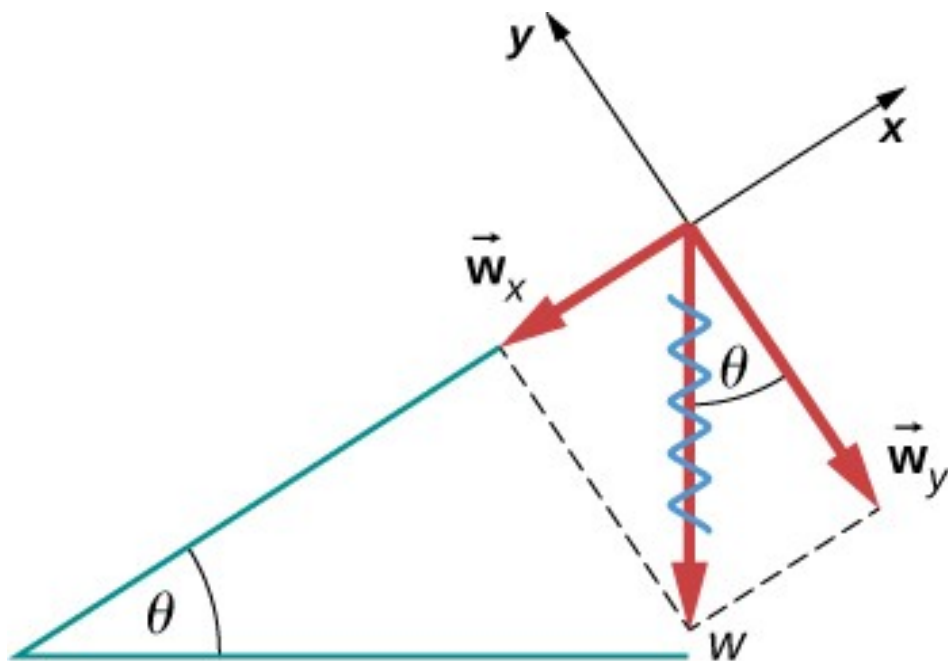

$$w_x = w \sin(\theta) = mg \sin(\theta)$$
$$w_y = w \cos(\theta) = mg \cos(\theta)$$

An object rests on an incline that makes an angle θ with the horizontal.

Strings and tension

FIGURE 5.24

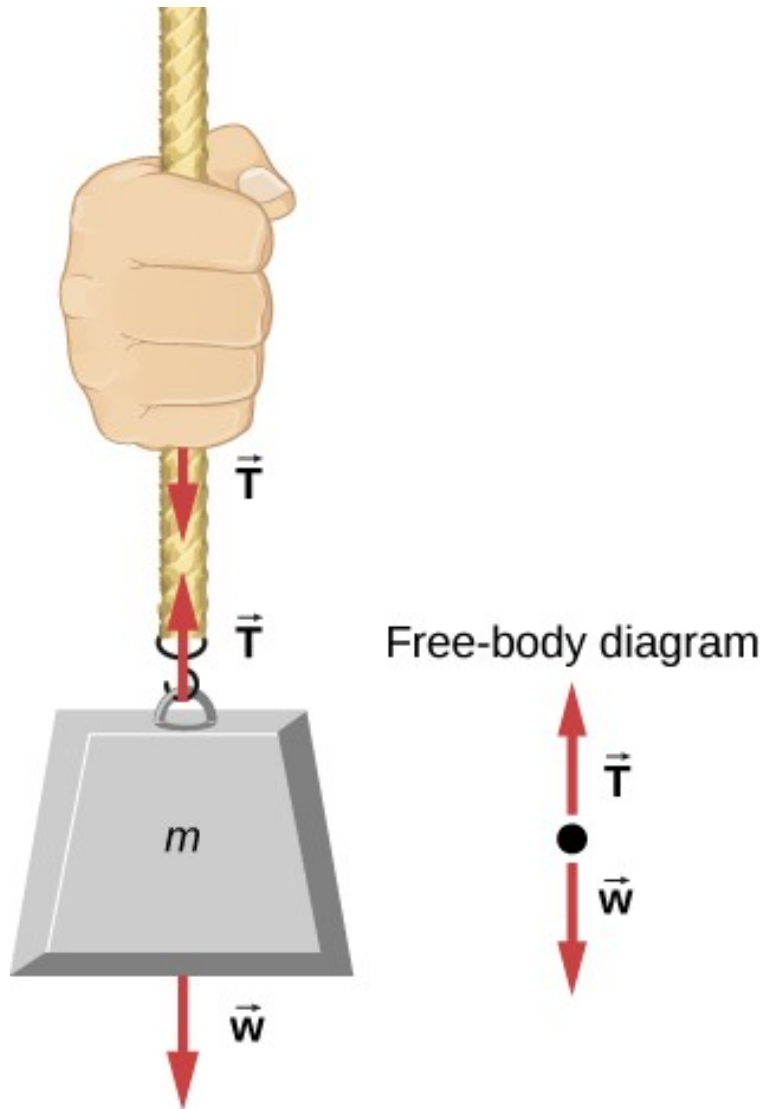

When a perfectly flexible connector (one requiring no force to bend it) such as this rope transmits a force, that force must be parallel to the length of the rope, as shown. By Newton's third law, the rope pulls with equal force but in opposite directions on the hand and the supported mass (neglecting the weight of the rope). The rope is the medium that carries the equal and opposite forces between the two objects. The tension anywhere in the rope between the hand and the mass is equal. Once you have determined the tension in one location, you have determined the tension at all locations along the rope.

FIGURE 5.25

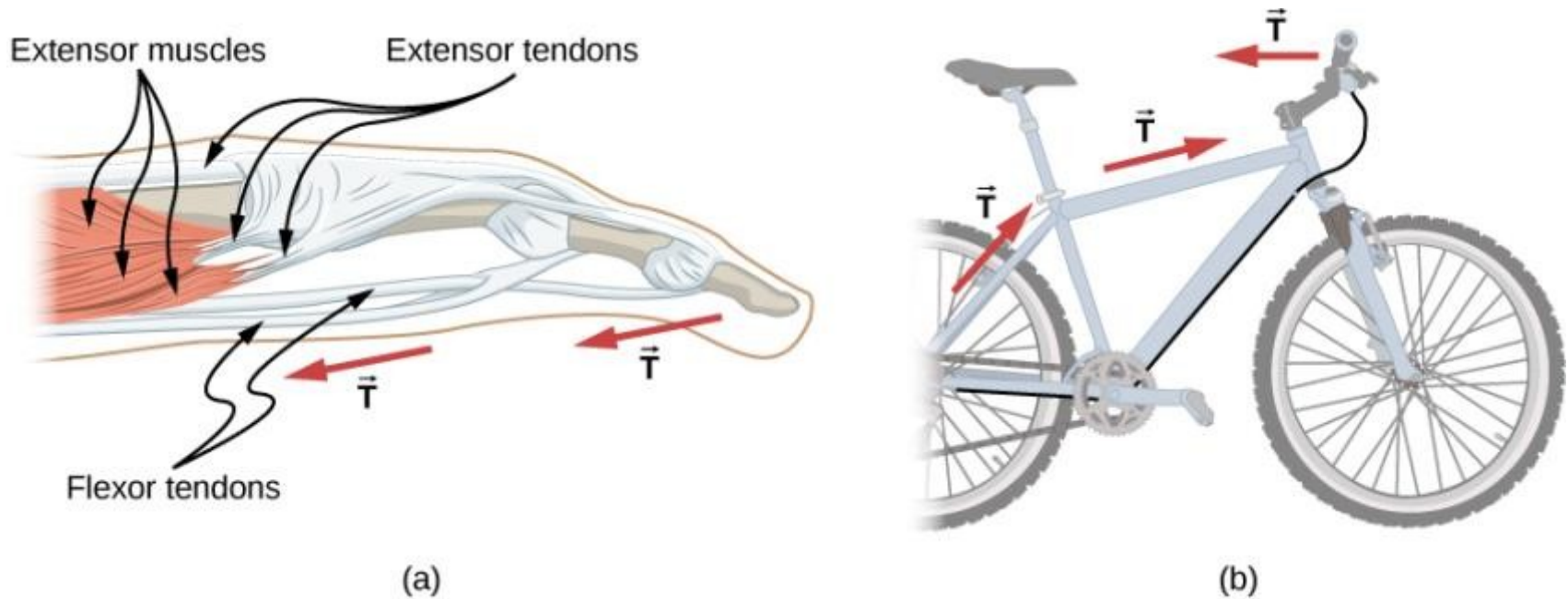

- a) Tendons in the finger carry force T from the muscles to other parts of the finger, usually changing the force's direction but not its magnitude (the tendons are relatively friction free).
- b) The brake cable on a bicycle carries the tension T from the brake lever on the handlebars to the brake mechanism. Again, the direction but not the magnitude of T is changed.

FIGURE 5.26

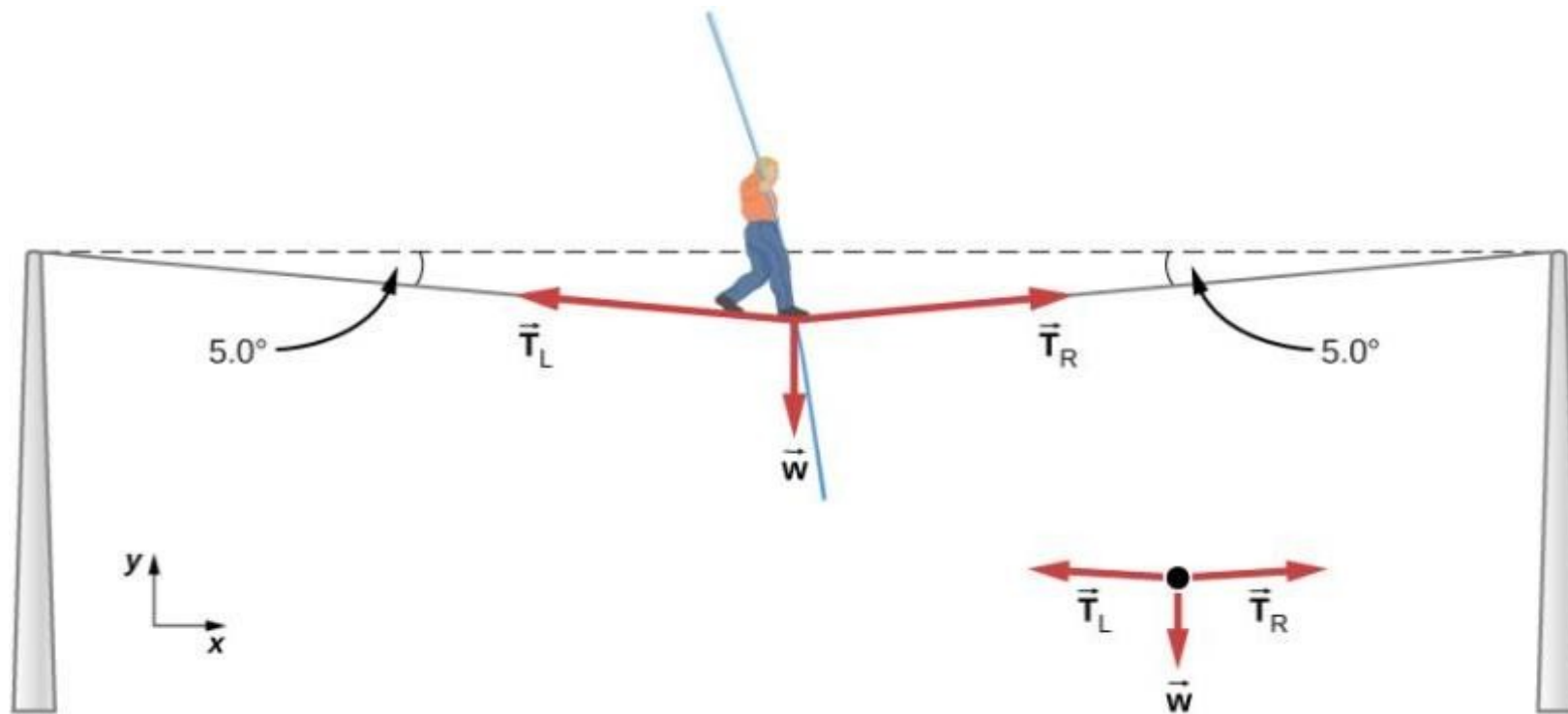

The weight of a tightrope walker causes a wire to sag by 5.0° . The system of interest is the point in the wire at which the tightrope walker is standing.

FIGURE 5.27

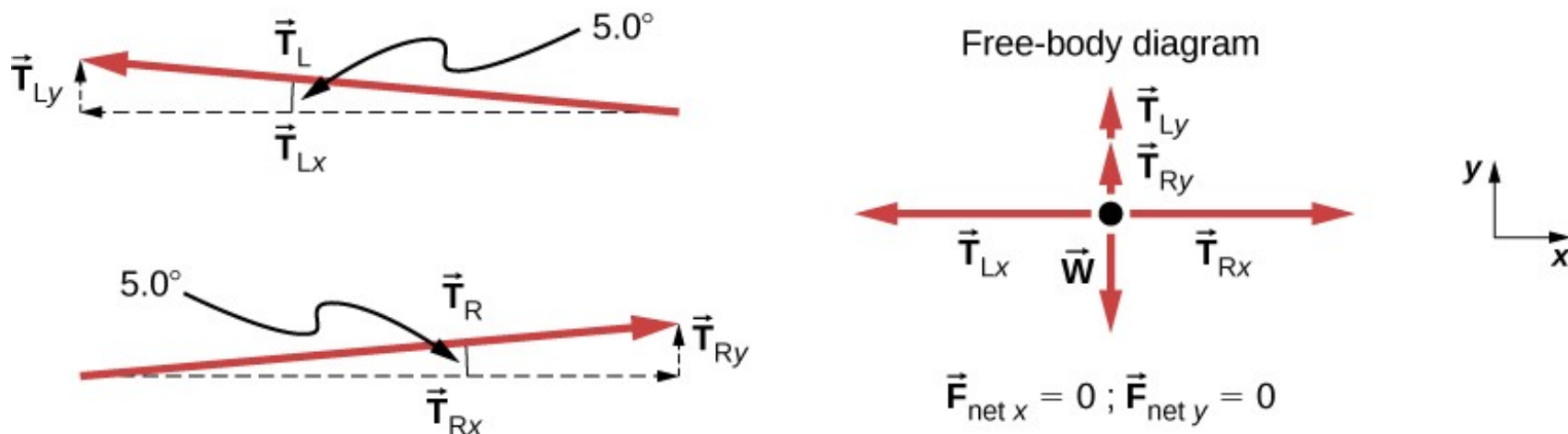

When the vectors are projected onto vertical and horizontal axes, their components along these axes must add to zero, since the tightrope walker is stationary. The small angle results in T being much greater than w .

FIGURE 5.28

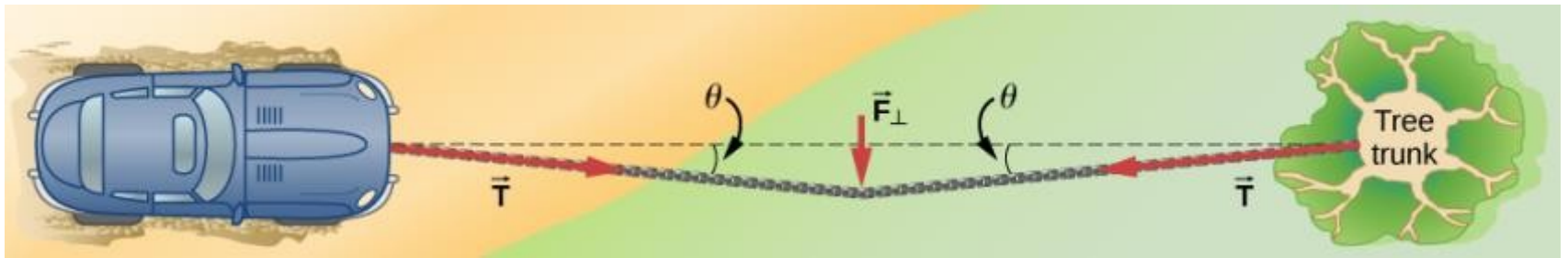

We can create a large tension in the chain—and potentially a big mess—by pushing on it perpendicular to its length, as shown.

FIGURE 5.32

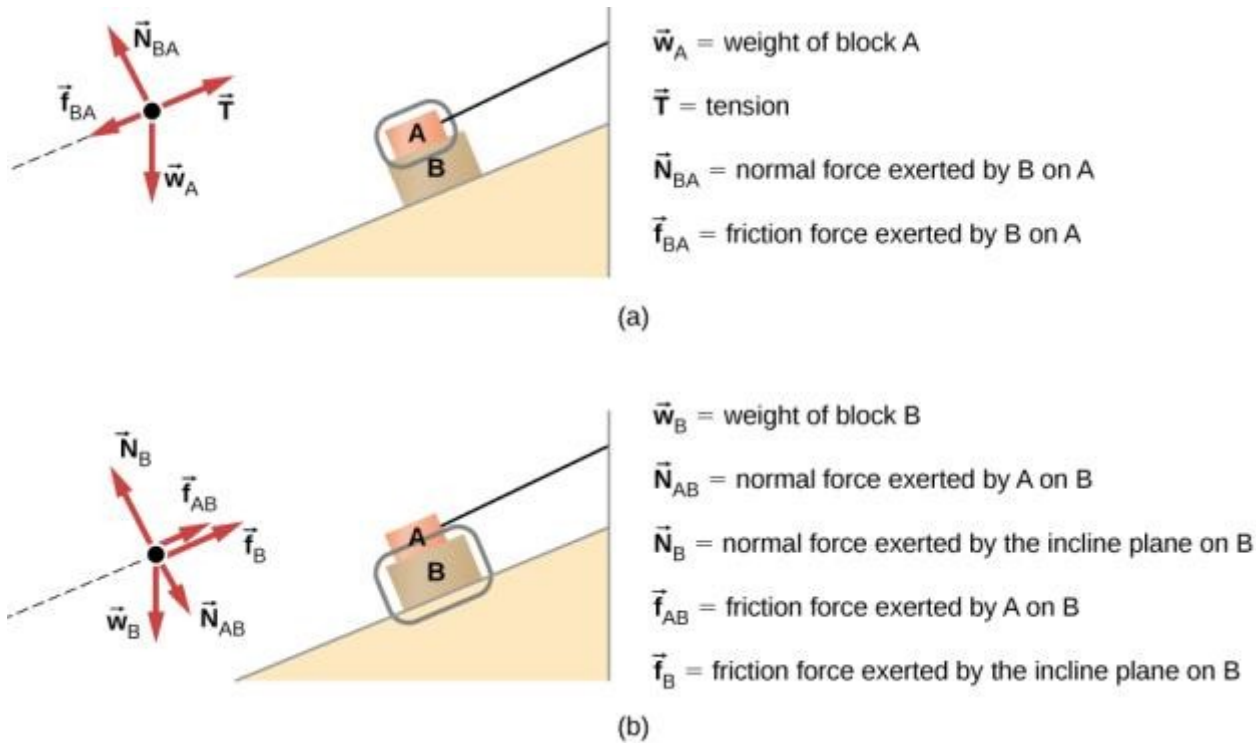

- a) The free-body diagram for isolated object A.
- b) The free-body diagram for isolated object B. Comparing the two drawings, we see that friction acts in the opposite direction in the two figures. Because object A experiences a force that tends to pull it to the right, friction must act to the left. Because object B experiences a component of its weight that pulls it to the left, down the incline, the friction force must oppose it and act up the ramp. Friction always acts opposite the intended direction of motion.

EXAMPLE 5.16.1

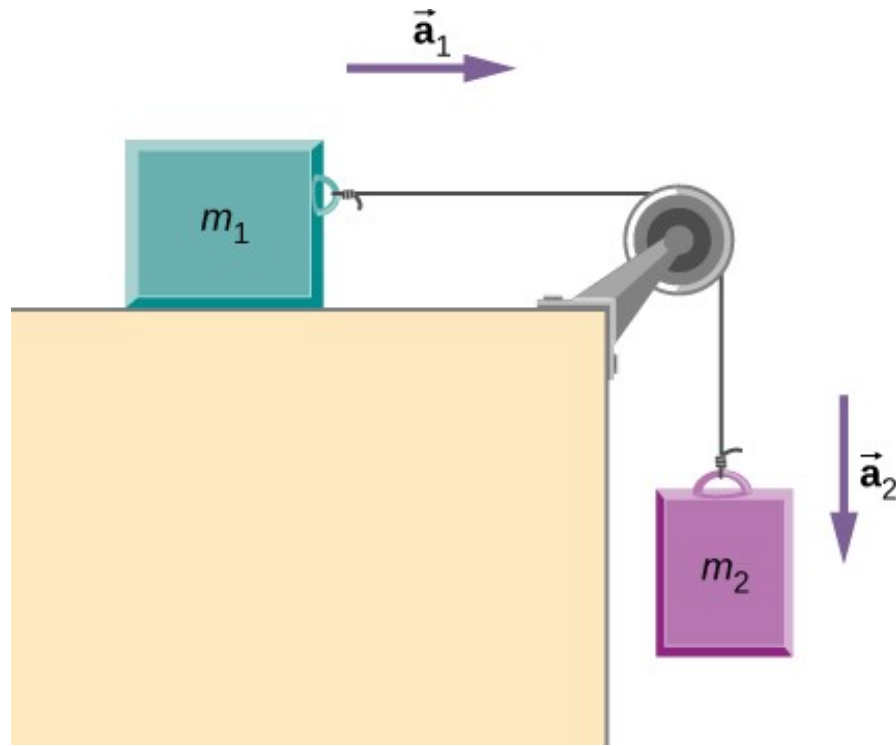

EXAMPLE 5.16.2

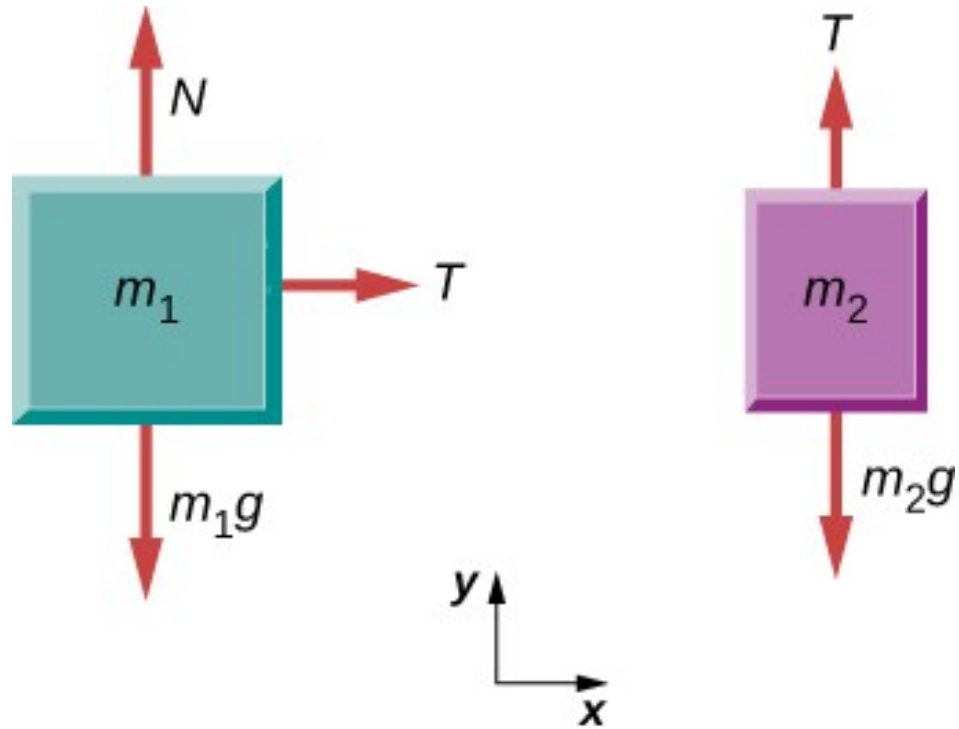

EXAMPLE 5.16.3

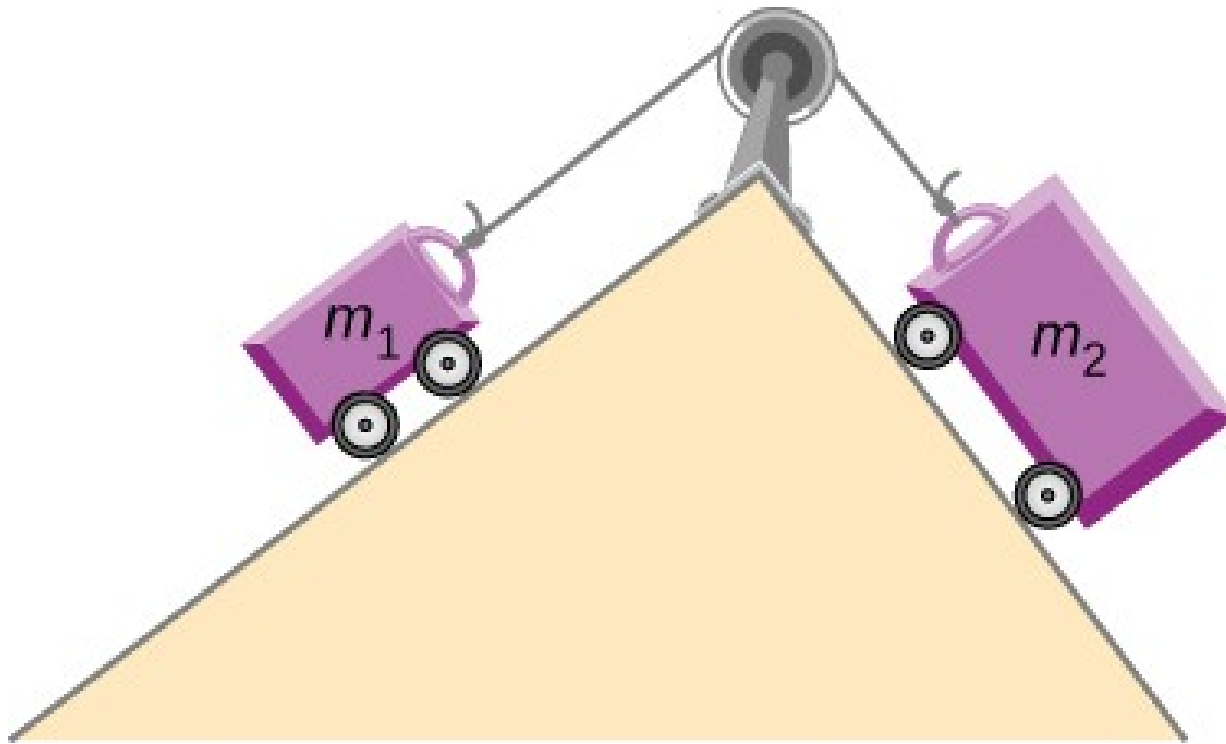

EXERCISE 40

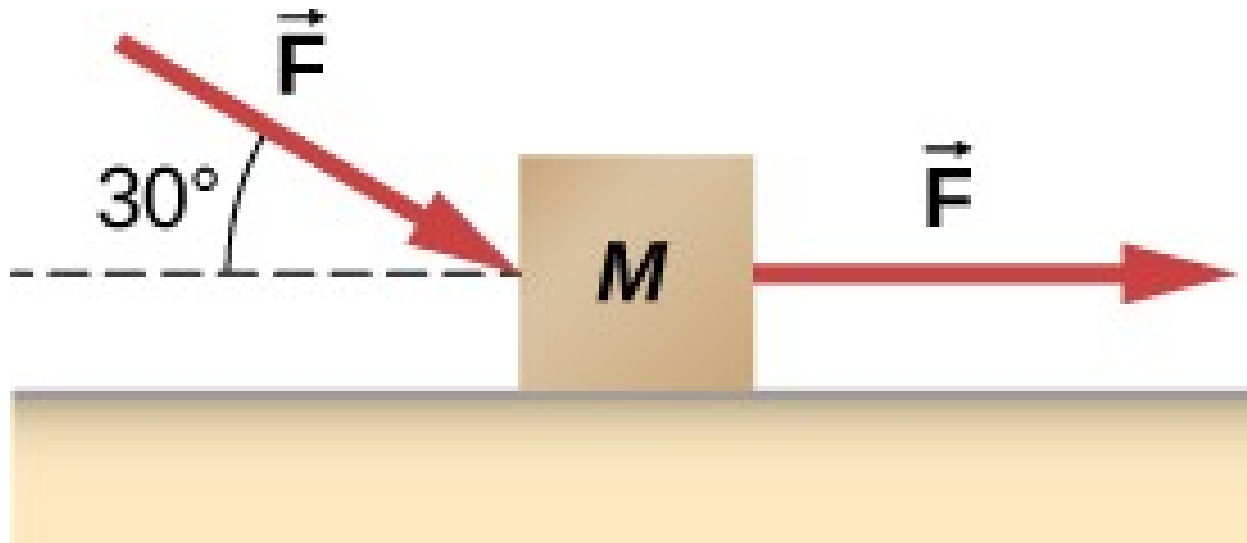

Springs

FIGURE 5.29

A spring exerts its force proportional to a displacement, whether it is compressed or stretched.

- a) The spring is in a relaxed position and exerts no force on the block.
- b) The spring is compressed by displacement of the object and exerts restoring force .
- c) The spring is stretched by displacement of the object and exerts restoring force .

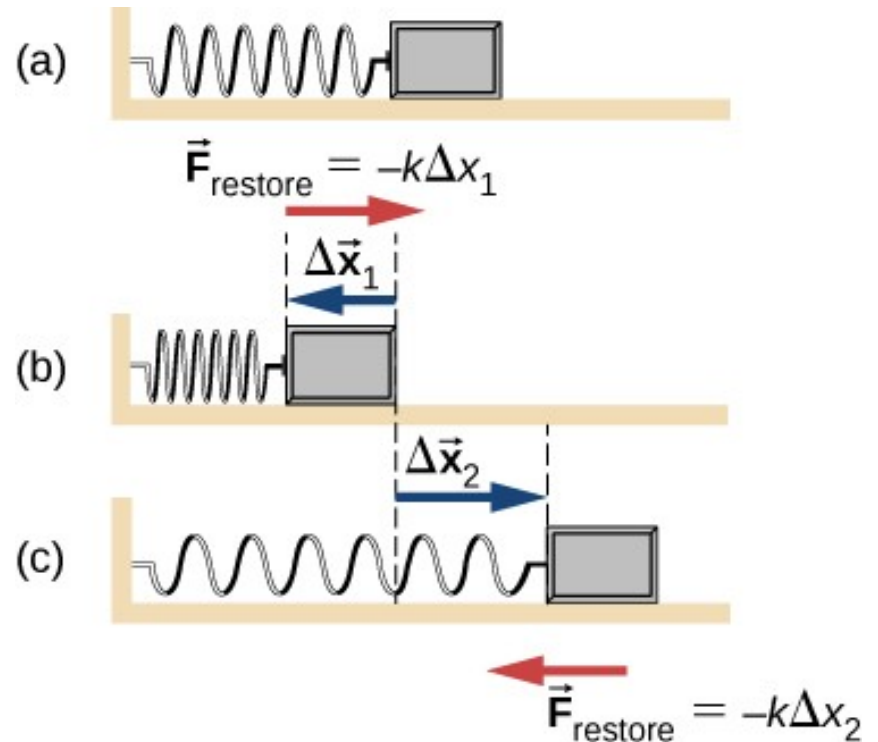



This OpenStax ancillary resource is © Rice University under a CC-BY 4.0 International license; it may be reproduced or modified but must be attributed to OpenStax, Rice University and any changes must be noted.