

A NEW EXPERIMENT TO SEARCH FOR NEUTRON→ANTINEUTRON TRANSITIONS AT HFIR REACTOR

YU. KAMYSHKOV

*Department of Physics and Astronomy, University of Tennessee,
401 Nielsen Physics Building, Knoxville TN 37996-1200, USA
E-mail: kamyshkov@utk.edu*

Experimental observation of nucleon instability is one of the key missing components required for the explanation of baryon asymmetry of the universe. Proton decays with the modes and rates predicted by the original (B-L) conserving SU(5) grand unification scheme are not observed experimentally. There are reasons to believe that (B-L) might not be conserved in nature, thus leading to the nucleon decay into lepton + (X) and to phenomena such as Majorana masses of neutrinos, neutrinoless double-beta decays, and most spectacularly the transitions of neutron to antineutron. The energy scale where these processes may occur is far beyond the reach of contemporary colliders. This scale is not predicted by theory therefore the existence of corresponding processes must be explored experimentally. In this paper we discuss motivation and a new experimental approach to searching for (B-L) violating transition of neutron to antineutron. A new search for $n \rightarrow \bar{n}$ can be performed in a reactor-based experiment at HFIR/ORNL with a sensitivity ~ 1000 times higher than in previous experiments.

1 Introduction

Searches for nucleon instability [1] are motivated by two outstanding concepts of contemporary physics: the interpretation of the baryon asymmetry of the universe (BAU) [2,3] and the idea of Unification of particles and forces [4,5] that both lie beyond the Standard Model (SM). But even within the concept of the Standard Model, baryon number is not conserved at the non-perturbative level [6]. The latter non-conservation is so weak at the present temperature of the universe that it does not lead to directly observable nucleon decay effects.

In spite of significant experimental attempts nucleon instability (other than β -decay) so far has not been discovered [7] suggesting further experimental efforts with increased mass of detectors [8] and the experiments in alternative directions [9]. One such possible alternative experiment is new sensitive searches for neutron to antineutron transition [10] that can explore stability of the matter at a lifetime scale an order of magnitude beyond the reach of contemporary nucleon decay experiments.

2 Motivation

Let us discuss the motivation for new neutron-antineutron transition search. Conservation of angular momentum in nucleon decay (nucleon spin 1/2) requires fermions to appear in the final state. Leptons: e , μ , three neutrinos and their antiparticles are the only known fermions the nucleon can decay into. Two possibilities exist here: $\Delta B = \Delta L$ or $\Delta B = -\Delta L$ (B and L are total baryon and lepton numbers respectively). The first possibility would lead to the conservation of $(B-L)$ and the second to processes that violate $(B-L)$ conservation by two units. The most stringent nucleon decay limits are experimentally established [7, 8, 11] for nucleon decay modes where $(B-L)$ is conserved such as $p \rightarrow e^+ + \pi^0$, $p \rightarrow \bar{\nu} + K^+$, $p \rightarrow \mu^+ + K^0$, etc. The failure to observe these decay modes has ruled out the original SU(5) [5] and one-step-breaking SO(10) [12] unification models. It is important to notice that in the original SU(5) model, as well as in the Standard Model, $(B-L)$ is strictly conserved at perturbative and non-perturbative levels. A new generation of experiments with huge-mass detectors [8] is needed to continue to test the stability of nucleons with respect to the $(B-L)$ conservation. We suggest that the possibility of $(B-L)$ non-conservation should be also equally addressed by future experiments.

Why might $(B-L)$ not be conserved? Naively one would expect that $(B-L)$ number be violated: the number of neutrons in our laboratory samples is in excess of equal number of protons and electrons. However, most leptons in the universe likely exist as, yet undetected, relic ν and $\bar{\nu}$ radiation similar to cosmic microwave background radiation of photons. Thus, the conservation of $(B-L)$ on a scale of the whole universe remains an open question.

We know that global and local conservation of electric charge is due to the existence of massless gauge vector field of photons [13]. Can $(B-L)$ be conserved in a similar way? That would imply the existence of “special photons” coupled to “ $(B-L)$ charge”. From Equivalence Principle tests [14] one can exclude the existence of massless long-range gauge field of $(B-L)$ photons at a level of interaction strength $< 10^{-12}$ of the gravitational strength [15]. It is interesting to notice that “baryonic photons” that would be responsible for the conservation of baryon charge are excluded from the same tests only at the level of $\sim 10^{-10}$ [16]. From this point of view the conservation of $(B-L)$ looks very unnatural.

In nucleon decay processes (with $\Delta B = -1$) the non-conservation of $(B-L)$ implies the existence of transitions of the type $N \rightarrow lepton + X$ with $\Delta(B-L) = -2$. The conservation of $(B-L)$ corresponds to $N \rightarrow antilepton + X$ transitions. If $(B-L)$ can be violated by two units, it is natural to assume, as also follows from the Unification models [17, 18], that processes with $|\Delta L| = 2$ and $|\Delta B| = 2$ are also the components of physics of the energy scale where $(B-L)$ is violated. Examples of

such processes would be heavy Majorana neutrinos with $|\Delta L|=2$ transitions of $\nu \leftrightarrow \bar{\nu}$ and transitions of $n \leftrightarrow \bar{n}$ with $|\Delta B|=2$. In Unification models of SO(10) type, massive Majorana neutrinos with $|\Delta L|=2$ transitions violating (B-L) by two units can generate the masses of conventional neutrinos through the “see-saw” mechanism [18]. Thus, the explanation of the masses of neutrinos can be linked with (B-L) and B non-conservation.

Since 1973, when (B-L) non-conservation was first considered theoretically [4], it has been discussed within the framework of Unification models in a number of theoretical papers [17, 19, 20, 12]. In the left-right symmetric SO(10) unification models, violation of (B-L) arises at the same energy scale where the left-right symmetry is restored [4, 17, 19]. Thus, (B-L) non-conservation is related to searches of right-handed currents and W_R vector bosons. Present experimental lower limits for W_R mass [7] are in TeV-range. For dimensional reasons, if $n \rightarrow \bar{n}$ transitions would be experimentally observed beyond the existing experimental limits, the energy scale of corresponding (B-L) violation and L-R restoration will be $\sim 10^5-10^6$ GeV.

Probably the most compelling argument for the existence of (B-L) non-conservation in nature follows from the theoretical observation [21] that electroweak non-perturbative “*sphaleron*” mechanism in the early universe would *erase* the observed baryon asymmetry if (B-L) is globally conserved. Although theoretical efforts are being made [22] to understand how BAU can be generated by (B-L) conserving processes at the temperatures below the unification scale, it is more natural to assume that (B-L) *non-conservation* takes place at the energies above the electro-weak scale. In this sense, experimental discovery of the nucleon decay into “standard” decay modes like $p \rightarrow \pi^0 + e^+$ or $p \rightarrow K^0 + \mu^+$ with conservation of (B-L) would leave BAU unexplained.

As was pointed out by Gell-Mann and Pais in 1955 [23], the only conservation law of nature that would forbid the $n \rightarrow \bar{n}$ transition is the conservation of *baryon number*. In 1970, $n \rightarrow \bar{n}$ transition was considered by Kuzmin as a possible explanation of BAU [3]. In the 1980s, it was suggested by Glashow in the context of SU(5) models [24] and independently by Marshak and Mohapatra [17] in the context of left-right symmetric models that the $n \rightarrow \bar{n}$ transition could lead to theoretical unification schemes complementary or alternative to those exploiting the (B-L) conserving proton decay mechanism. In particular, Marshak and Mohapatra pointed out that there is an intimate connection between a non-vanishing Majorana mass for neutrinos and a possibility of the $\Delta(B-L) = -2$ in $n \rightarrow \bar{n}$ transition. The recent experimental indication of existence of neutrino mass [25] therefore strengthens the case for a new dedicated search for $n \rightarrow \bar{n}$ oscillation at the reactors.

3 New $n \rightarrow \bar{n}$ search experiment

Observation of $n \rightarrow \bar{n}$ transitions would be a spectacular manifestation of a new physics corresponding to (B-L) non-conservation at energy scale 10^5 - 10^6 GeV. The experimental signature of appearance of antineutrons in a thermal-energy neutron beam is unambiguous and background free as claimed in the previous state-of-the-art $n \rightarrow \bar{n}$ experimental search performed with free cold neutrons by the Heidelberg-ILL-Padova-Pavia Collaboration [26] at ILL/RHF reactor in Grenoble. The $n \rightarrow \bar{n}$ transition probability for free neutrons in the absence of external fields (that affect neutrons and anti-neutrons differently) is [17] $P_{n\bar{n}} = (t/\tau_{n\bar{n}})^2$ where $\tau_{n\bar{n}}$ is a characteristic transition time determined by the physics at energy scale 10^5 - 10^6 GeV. The experimental limit on free-neutron transition time of $\tau_{n\bar{n}} \geq 8.6 \cdot 10^7$ seconds obtained in $n \rightarrow \bar{n}$ search experiment [26] is equivalent to the limit of $\sim 6.5 \cdot 10^{31}$ years obtained in the searches of intranuclear $n \rightarrow \bar{n}$ transitions in nucleon-decay experiments [7, 27]. The equivalence of these two limits is due to a dimensional suppression factor R in intranuclear transitions that relates these two processes as $\tau(\text{intranuclear}) = R \cdot \tau_{n\bar{n}}^2(\text{free})$ with $R \sim 2 \cdot 10^{23} \text{ sec}^{-1}$ [27], where $\tau(\text{intranuclear})$ is a regular exponential lifetime. The factor R is known theoretically with an accuracy of $\sim \pm (20-25) \%$ [27]. This equivalence clearly demonstrates the potential of the reactor-based search with free neutrons where sensitivity increases with the square of observation time t . Present technology (focusing neutron reflector and cold neutron moderator) and existing sources of neutrons (e.g. HFIR reactor at ORNL with the world highest thermal flux of $\sim 1.5 \cdot 10^{15} \text{ n}\cdot\text{cm}^{-2}\cdot\text{s}^{-1}$) allow to increase the sensitivity of $n \rightarrow \bar{n}$ search by factor of $\sim 1,000$ [10] and thus to explore the stability of matter to the level of $\sim 10^{35}$ years in terms of intranuclear $n \rightarrow \bar{n}$ transitions. For comparison, the Super-Kamiokande detector after ~ 10 years of running can potentially reach corresponding intranuclear $n \rightarrow \bar{n}$ transition limit of $\tau(\text{intranuclear})$ of only $(1-2) \cdot 10^{33}$ years [28].

Discovery potential ($D.P.$) of the $n \rightarrow \bar{n}$ search experiment should be defined as a product of the number of neutrons per second in the beam and the square of the neutron flight time to annihilation target. Discovery potential in a new $n \rightarrow \bar{n}$ search experiment proposed for 100-MW HFIR reactor at Oak Ridge National Laboratory [29] can be improved by using ^{58}Ni coated neutron-focusing reflector with optimized shape [10]. The conceptual layout of such experiment is shown in Figure 1. A large focusing reflector intercepts slow neutrons emitted from the cold neutron source in the large solid angle and concentrates them on the annihilation-detector target situated at an optimized distance of 200-500 m from the source.

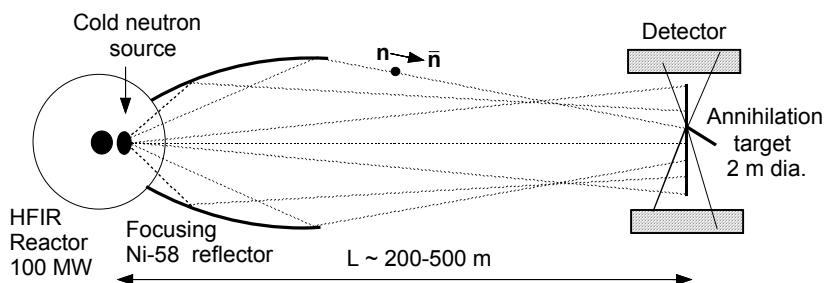

Figure 1. Conceptual layout of $n \rightarrow \bar{n}$ search experiment with focusing reflector (not to scale).

Figure 2 shows cross-section of the HFIR reactor at ORNL where $n \rightarrow \bar{n}$ search experiment can be implemented at the HB-3 beam line equipped with new cold neutron moderator.

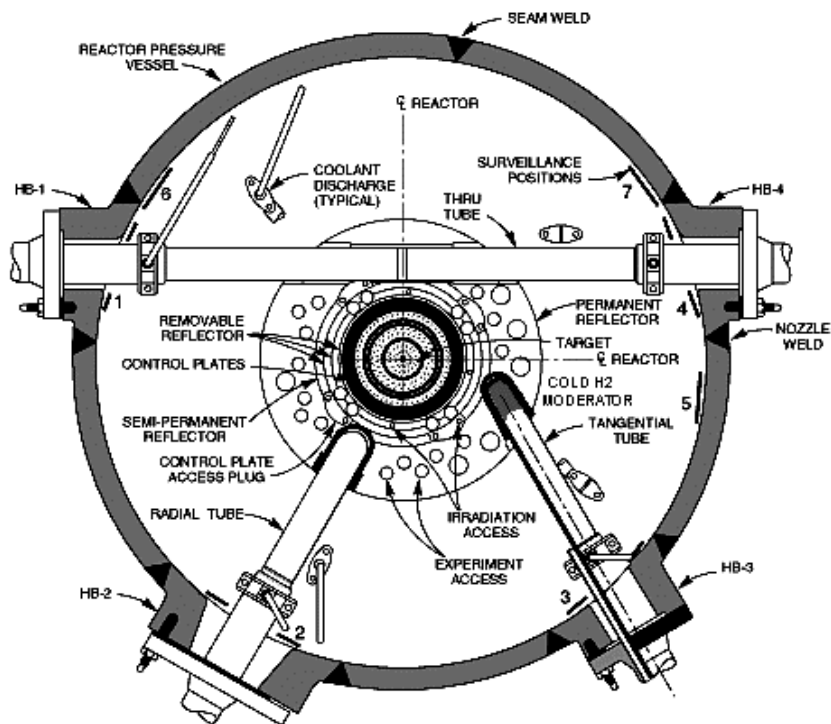

Figure 2. Section view of ORNL/HFIR reactor core. In the $n \rightarrow \bar{n}$ search experiment the cold supercritical hydrogen moderator should be installed in the HB-3 beam tube.

One can show, neglecting the effect of gravity, that the probability of observation of an antineutron in the experiment with optimized focusing reflector is proportional to $D.P. \sim L^2 / T^{3/2}$, where L is the distance between point of reflection and annihilation detector and T is an effective temperature of the thermalized neutron spectrum. This should be compared with the discovery potential for a layout without the focusing reflector where $D.P. \sim 1/T^{1/2}$. With the advanced layout the large length of the experiment and the low temperature of neutrons would result in substantial increase of the discovery potential. More comprehensive Monte-Carlo simulations including the effect of gravity [10] show that discovery potential of HFIR-based experiment with cold supercritical hydrogen moderator [30] in HB-3 beam pipe (see Figure 2) can be factor of ~ 400 higher than in ILL/RHF-based experiment [26]. Thus, *a single day* of operation at HFIR in the new $n \rightarrow \bar{n}$ search experiment [29] is equivalent to *one year* in the previous ILL/RHF-based search. Table 1 compares essential features of the new-proposed HFIR experiment [29] in the HB-3 beam port with previous ILL/RHF-based experiment [26].

Table 1. Comparison of the major parameters of a new $n \rightarrow \bar{n}$ search experiment proposed for HB-3 beam line at High Flux Isotope Reactor at Oak Ridge National Laboratory with the previous $n \rightarrow \bar{n}$ search experiment performed in 1989-91 at RHF Reactor at ILL/Grenoble.

Neutron source	RHF/Grenoble	HFIR/ORNL
Reference	[26]	[29]
Status of experiment	Completed	Proposed (HB-3 beam)
Reactor power, MW	58	(85) 100
Reactor's peak thermal n-flux	$1.4 \cdot 10^{15}$ (n/cm ² /s)	$1.5 \cdot 10^{15}$ (n/cm ² /s)
Moderator	Liquid D ₂	Supercritical H ₂
Source area	6×12 cm ²	~11 cm diameter
Target diameter	1.1 m	2.0 m
Flight path	76 m	300 m
Neutron fluence @ target	$1.25 \cdot 10^{11}$ n/s	$\sim 8.5 \cdot 10^{12}$ n/s
Average time of flight	0.109 s	0.27 s
Detector efficiency	0.48	~ 0.5
Operation time (s)	$2.4 \cdot 10^7$	$7 \cdot 10^7$ (~3 years)
Discovery potential per sec	$1.5 \cdot 10^9$ n·s ²	$6.2 \cdot 10^{11}$ n·s ²
$\tau_{\bar{n}}$ limit (90% CL)	$8.6 \cdot 10^7$ s	$3.0 \cdot 10^9$ s

The conceptual scheme of the antineutron annihilation detector (Figure 3) is similar to that used in the previous Heidelberg-ILL-Padova-Pavia experiment [26] at ILL/RHF in Grenoble. The annihilation target is a thin carbon-film membrane with almost 100% efficiency for antineutron annihilation and low efficiency for (n,γ) conversion. Final states of nucleon-antinucleon annihilation are well understood

mainly due to the LEAR studies and can be accurately modeled [31]. Average final state has five pions originating in the annihilation target. A tracking detector reconstructs the vertex of the candidate event to verify its origin. A calorimeter is used for triggering and for measurement of the total energy deposit (below ~ 1.8 GeV). Detector is surrounded by a cosmic veto scintillator counter system to reduce trigger rate and to remove possible cosmic ray background.

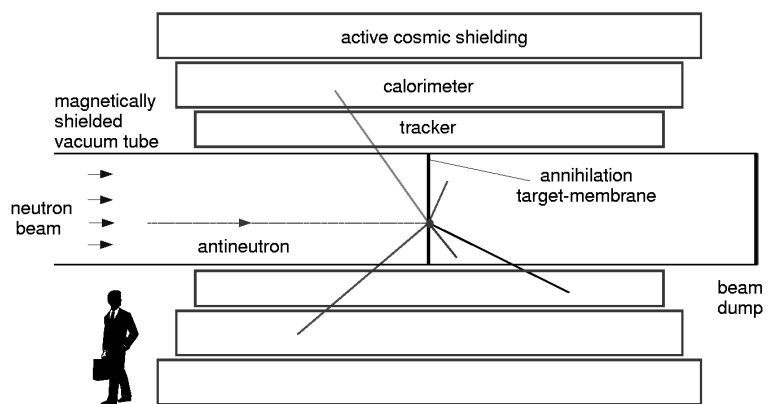

Figure 3. Conceptual view of the antineutron annihilation detector for $n \rightarrow \bar{n}$ search experiment.

The ^{58}Ni coating of the focusing reflector does not require the quality needed in the case of the conventional neutron guides, since neutrons undergo essentially only single reflection. Vacuum in the flight tube should be better than 10^{-4} Pa.

Since the Earth magnetic field would suppress the $n \rightarrow \bar{n}$ transition it must be compensated down to a few nano-Tesla over the entire flight volume. Following the recommendation of [26] both active (compensating coils) and passive (permalloy) screens can be used to achieve required field compensation. An active magnetic field compensation system provides cross check by “switching off” the effect in case if antineutron signature is observed.

It was pointed out in paper [32] that existence of $n \rightarrow \bar{n}$ transitions would provide a unique opportunity to test the CPT-theorem with unprecedented accuracy by looking at the mass difference Δm of neutron and antineutron. Such mass difference (or a small gravitational non-equivalence of neutron and antineutron) will suppress the $n \rightarrow \bar{n}$ transition for free neutrons but will be too small to produce a

sizable additional effect in intranuclear transitions where a very large suppression is already present due to the difference of nuclear potentials for neutron and antineutron. Therefore, two measurements are required: one with free neutrons in the reactor experiment and the other with bound neutrons in intranuclear transitions [32]. The second experiment can be replaced by a reactor-based measurement with small controllable variation of the magnetic field. Since the ultimate sensitivity to Δm of the reactor-based experiment is $\Delta m < \hbar/\Delta t$, with a neutron flight time $\Delta t \sim 0.3$ sec (for HFIR-based experiment), the smallest achievable value of $\Delta m/m$ can be few orders of magnitude lower than $m_{Nucleon}/m_{Plank}$.

4 Conclusion

A reactor search for $n \rightarrow \bar{n}$ transition is a very sensitive method for detection of (B-L) non-conserving processes. The proposed new experiment to search for $n \rightarrow \bar{n}$ transition at HFIR/ORNL reactor could result in an equivalent experimental limit of 10^{35} years for baryonic intranuclear stability. Such limit is not attainable by any other existing experimental method.

If $n \rightarrow \bar{n}$ transitions are observed, it will reveal phenomena leading to new physics at the energy scale of 10^5 – 10^6 GeV, i.e., beyond the range of colliders. New symmetry principles determining the history of the universe during the first moments of creation might be established; the left-right symmetry, broken in the Standard Model, may be found restored. The discovery of $n \rightarrow \bar{n}$ transition would provide a major constraint on unification models and contribute to the understanding of baryon asymmetry in the universe. If and when such phenomenon is established, the subsequent experiments with $n \rightarrow \bar{n}$ transition should allow a most precise test of CPT invariance and/or test of gravitational equivalence of baryonic matter and antimatter.

5 Acknowledgements

I would like to thank Professor W. M. Bugg for many useful and encouraging discussions.

References

1. Goldhaber M., Search for Nucleon Instability (Origin and History), in the *Proceedings of International Workshop on Future Prospects of Baryon Instability Search in p-Decay and $n \rightarrow \bar{n}$ Oscillation Experiments*, Oak Ridge, 1996, pp.1–6.

2. Sakharov A.D., *JETP Lett.* **5** (1967) pp.24–27; *Sov. Phys. Usp.* **34** (1991) pp. 392–393.
3. Kuzmin V.A., *JETP Lett.* **12** (1970) p.228; *ZhETF Pis. Red.* **12**, No. 6 (1970) p. 335; *Izvestiya AN SSSR ser. Phys.* **35** (1971) 2088.
4. Pati J. and Salam A., *Phys.Rev.* **D8** (1973) 1240; *Phys. Rev. Lett.* **31** (1973) pp. 661-664; *Phys. Rev.* **D10** (1974) pp. 275–289.
5. Georgi H. and Glashow S.L., *Phys. Rev. Lett.* **32** (1974) pp. 438-441.
6. 't Hooft G., *Phys. Rev. Lett.* **37**(1976) 8-11; *Phys. Rev.* **D14** (1976) pp. 3432-3450.
7. D.E. Groom et al. (Particle Data Group), Review of Particle Physics, *Eur. Phys. Jour.* **C15** (2000) 1.
8. See Proceedings of the International Workshop on *Next Generation Nucleon Decay and Neutrino Detector*, Stony Brook, September 23-25, 1999.
9. Kamyshkov Yu., Nucleon Instability and (B–L) non-conservation, in the *Proceedings of the International Workshop on Next Generation Nucleon Decay and Neutrino Detector*, Stony Brook, September 23-25, 1999.
10. Kamyshkov Yu. et al. in the *Proceedings of the ICANS-XIII meeting*, PSI, Villigen, 1995, p.843; Kamyshkov Yu., in the *Proceedings of CIPANP 97 (Intersections between particle and nuclear physics)*, Big Sky 1997, pp. 335-341; Kamyshkov Yu., in the *Proceedings of Workshop on Physics Beyond the Standard Model*, Tegernsee 1997, pp. 542-553.
11. Shiozawa M., Mini-review on Nucleon Decay, in the *Proceedings of the XXXth International Conference on High Energy Physics*, July 27 - August 2, 2000, Osaka, Japan.
12. Pati J., Discovery of Proton Decay: a Must for Theory, a Challenge for Experiment, hep-ph/0005095 v2, 25 May 2000.
13. Okun L.B., *Leptons and Quarks*, Moscow “Nauka”, 1981, pp. 152-158.
14. Eötvös E. v., Pekar D., and Fekete E., *Ann. d. Phys.* **68** (1922) 11; Roll P. G., Krotkov R., and Dicke R. H., *Ann. Phys. (U.S.A)* **26** (1964) 442; Braginsky V. G. and Panov V. I., *Sov. Phys. JETP* **34** (1971) 464.
15. Sakharov A. D., Baryon Asymmetry of the Universe, Reprint of the review paper presented at the *A. A. Friedmann Centenary Conference*, Leningrad, USSR, June 22-26, 1988, published in *Sov.Phys.Usp.* **34**, No.5 (1991) 417.
16. Lee T.D., Yang C.N., *Phys.Rev.* **98** (1955) 1501; Pati J.C. and Salam A., *Phys.Rev.Lett.* **31** (1973) 661.
17. Mohapatra R. and Marshak R., *Phys. Lett.* **91B** (1980) 222; *Phys. Rev. Lett.* **44** (1980) 1316; *Phys. Lett.* **94B** (1980) 183.
18. Gell-Mann M., Ramond P. and Slansky R., in *Supergravity, Proceedings of the Workshop*, Stony Brook, New York, 1979, P. van Nieuwenhuizen and D. Freedman, eds. (North-Holland, Amsterdam, 1979), p. 315; Yanagida T., in *Proceedings of the Workshop on the Unified Theories and Baryon Number in the Universe*, Tsukuba, Japan, 1979, O. Sawada and A. Sugamoto, eds. (KEK

- Report No. 79-18, Tsukuba, 1979), p. 95; Mohapatra R. N. and Senjanovic G., *Phys. Rev. Lett.* **44** (1980) 912.
19. Davidson A., *Phys. Rev.* **D20** (1979) 776.
 20. Wilczek F. and Zee A., *Phys. Lett.* **88B** (1979) 311; Chang L.N. and Chang N.P., *Phys. Lett.* **B92** (1980) 103; Buccella F. et al., *Phys. Lett.* **B320** (1994) 313.
 21. Kuzmin V., Rubakov V., and Shaposhnikov M., *Phys. Lett.* **155B** (1985) 36; Rubakov V. and Shaposhnikov M., *Sov.Phys.Usp.* **39** (1996) 461.
 22. see review by Riotto A. and Trodden M., Recent Progress in Baryogenesis, *Annu. Rev. Nucl. Sci.* **49** (1999) 35-75.
 23. Gell-Mann M. and Pais A., *Phys Rev.* **97** (1955) 1387.
 24. Glashow S. L., Harvard report, HUTP-79/A059 (1979).
 25. SuperKamiokande Collaboration, Fukuda Y. et al., *Phys. Rev. Lett.* **81** (1998) 1562; LSND Collaboration, Athanassopoulos C. et al., *Phys. Rev. Lett.* **77** (1996) 3082-3085.
 26. Baldo-Ceolin M. et al., *Z. Phys* **C63** (1994) 409.
 27. Alberico W. M., $n\bar{n}$ Suppression in Intranuclear Transitions (review) and references therein, in the *Proceedings of the International Workshop on the Future Prospects of Baryon Instability Search in Proton-Decay and $n \rightarrow \bar{n}$ Oscillation Experiments*, Oak Ridge, March 28-30, 1996; also recent Hufner J. and Kopeliovich B. Z., *Mod. Phys. Lett.* **A13** (1998) 2385.
 28. Stone J., Private Communication, 1996.
 29. Bugg W.M. et al., Letter of Intent to the Oak Ridge National Laboratory to search for the $n \rightarrow \bar{n}$ transition using a detector to be built at ORNL's High Flux Isotope Reactor, UTK-PHYS-96-L1, 1996.
 30. Selby D.L. et al., High Flux Isotope Reactor Cold Neutron Source Reference Design Concept, Report ORNL/TM-13498, May 1998.
 31. Golubeva E.S. et al., Antineutron Annihilation Event Generator for $n \rightarrow \bar{n}$ Search Experiment, in the *Proceedings of the International Workshop on the Future Prospects of Baryon Instability Search in Proton-Decay and $n \rightarrow \bar{n}$ Oscillation Experiments*, Oak Ridge, March 28-30, 1996.
 32. Abov Yu., Djeparov F., Okun L., *JETP Lett.* **39** (1984) 493-494; Okun L., Test of CPT, preprint ITEP-TH-55/96, hep-ph/9612247 (1996).